

INTERNATIONAL STANDARD

ISO
8764-1

Second edition
1999-09-15

Corrected and reprinted
2000-09-01

Assembly tools for screws and nuts — Screwdrivers for cross-recessed head screws —

Part 1: Driver points

*Outils de manœuvre pour vis et écrous — Tournevis pour vis à empreinte
cruiforme —*

Partie 1: Extrémités de tournevis



Reference number
ISO 8764-1:1999(E)

ISO 8764-1:1999(E)

Contents	Page
1 Scope	1
2 Normative references	1
3 Shapes and dimensions	1
4 Technical requirements	5
4.1 Material	5
4.2 Heat treatment and hardness	5
4.3 Finish	5
5 Inspection of dimensions	5
5.1 Inspection gauges for type PH points	5
5.2 Inspection gauges for type PZ points	7
6 Torque test	9
Annex A (informative) Explanation of choice of gauge dimensions for type PH points	12
Annex B (informative) "Reading guide" for inspection gauges for type PZ points	13

© ISO 1999

All rights reserved. Unless otherwise specified, no part of this publication may be reproduced or utilized in any form or by any means, electronic or mechanical, including photocopying and microfilm, without permission in writing from the publisher.

International Organization for Standardization
Case postale 56 • CH-1211 Genève 20 • Switzerland
Internet iso@iso.ch

Printed in Switzerland

Foreword

ISO (the International Organization for Standardization) is a worldwide federation of national standards bodies (ISO member bodies). The work of preparing International Standards is normally carried out through ISO technical committees. Each member body interested in a subject for which a technical committee has been established has the right to be represented on that committee. International organizations, governmental and non-governmental, in liaison with ISO, also take part in the work. ISO collaborates closely with the International Electrotechnical Commission (IEC) on all matters of electrotechnical standardization.

International Standards are drafted in accordance with the rules given in the ISO/IEC Directives, Part 3.

Draft International Standards adopted by the technical committees are circulated to the member bodies for voting. Publication as an International Standard requires approval by at least 75 % of the member bodies casting a vote.

International Standard ISO 8764-1 was prepared by Technical Committee ISO/TC 29, *Small tools*, Subcommittee SC 10, *Assembly tools for screws and nuts, pliers and nippers*.

This second edition cancels and replaces the first edition (ISO 8764-1:1992) in which information on points and gauges for type PZ points has been technically revised.

ISO 8764 consists of the following parts, under the general title *Assembly tools for screws and nut — Screwdrivers for cross-recessed head screws*:

- *Part 1: Driver points*
- *Part 2: General requirements, lengths of blades and marking of hand-operated screwdrivers*

Annexes A and B of this part of ISO 8764 are for information only.

Introduction

The revision of the pictorial representation established in this part of ISO 8764, both of the point and of the gauge of type PZ, was necessary in order to achieve the best possible representation and to eliminate different interpretations.

Assembly tools for screws and nuts — Screwdrivers for cross-recessed head screws —

Part 1: Driver points

1 Scope

This part of ISO 8764 specifies the shapes and dimensions, the technical requirements and torque test methods for the points of hand drivers and of machine-operated bits for cross-recessed head screws.

This part of ISO 8764 specifies two types of driver points as follows:

- type PH for type H recesses;
- type PZ for type Z recesses.

H and Z type recesses are specified in ISO 4757.

General requirements, lengths of blades and marking of hand-operated screwdrivers are given in ISO 8764-2.

2 Normative references

The following normative documents contain provisions which, through reference in this text, constitute provisions of this part of ISO 8764. For dated references, subsequent amendments to, or revisions of, any of these publications do not apply. However, parties to agreements based on this part of ISO 8764 are encouraged to investigate the possibility of applying the most recent editions of the normative documents indicated below. For undated references, the latest edition of the normative document referred to applies. Members of ISO and IEC maintain registers of currently valid International Standards.

ISO 4757:1983, *Cross recesses for screws*.

ISO 8764-2:1992, *Screwdrivers for cross-recessed head screws — Part 2: General requirements, lengths of blades and marking of hand-operated screwdrivers*.

3 Shapes and dimensions

The shapes and dimensions of the points shall conform with the requirements given in Figure 1 and Table 1 for type PH and Figure 2 and Table 2 for type PZ.

The axis of the point shall be concentric with the axis of the tool.

When a plated finish is used, the dimensions shall be met after plating.

Dimensions in millimetres

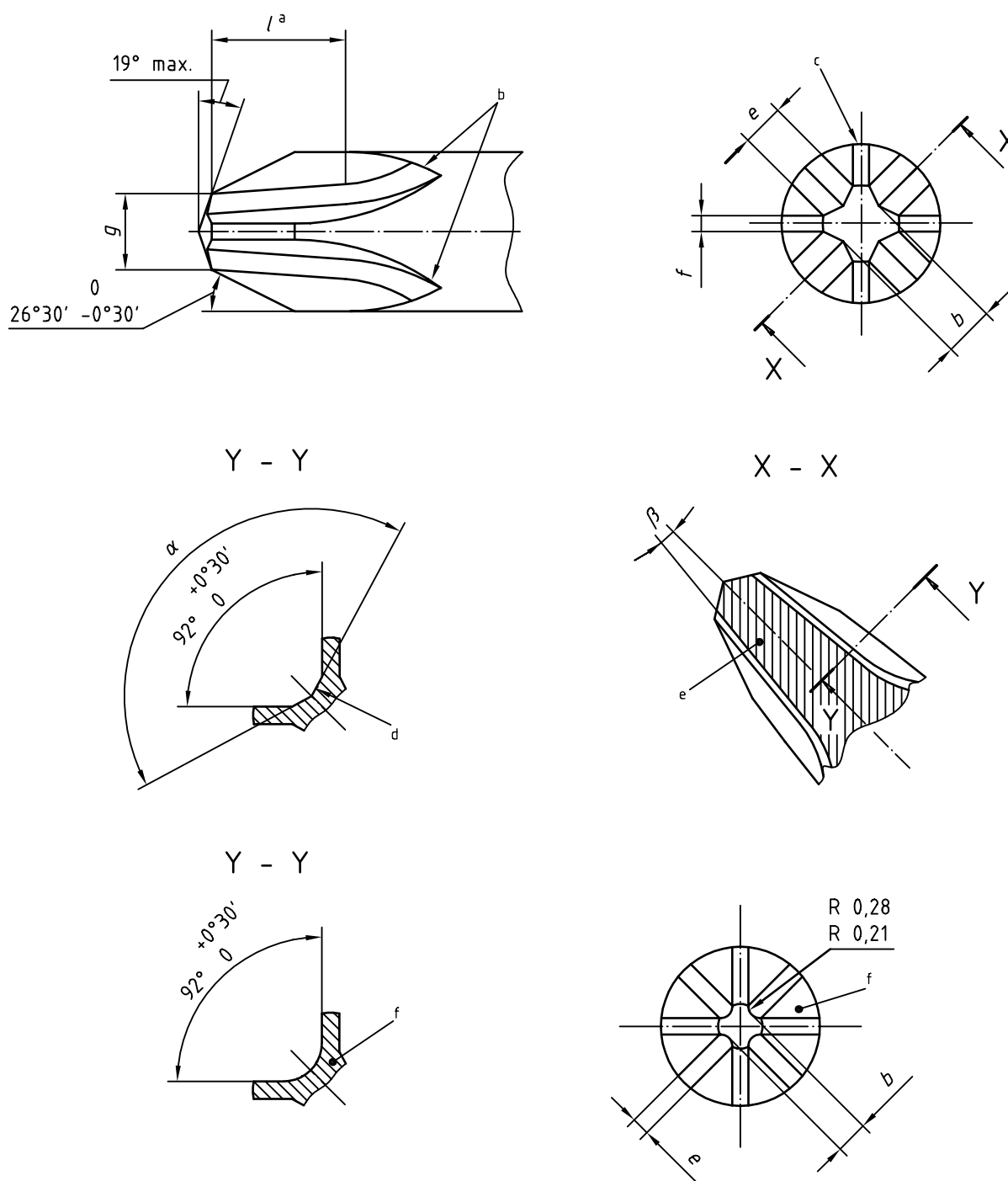

- a Length of straight part
- b Blending of flutes dependent on method of manufacture
- c Flutes equally spaced at 90°
- d For point No. 0, see detail below
- e Section Y-Y: true flute angle measured at right angles to straight part of length l
- f Point No. 0

Figure 1 — Type PH points

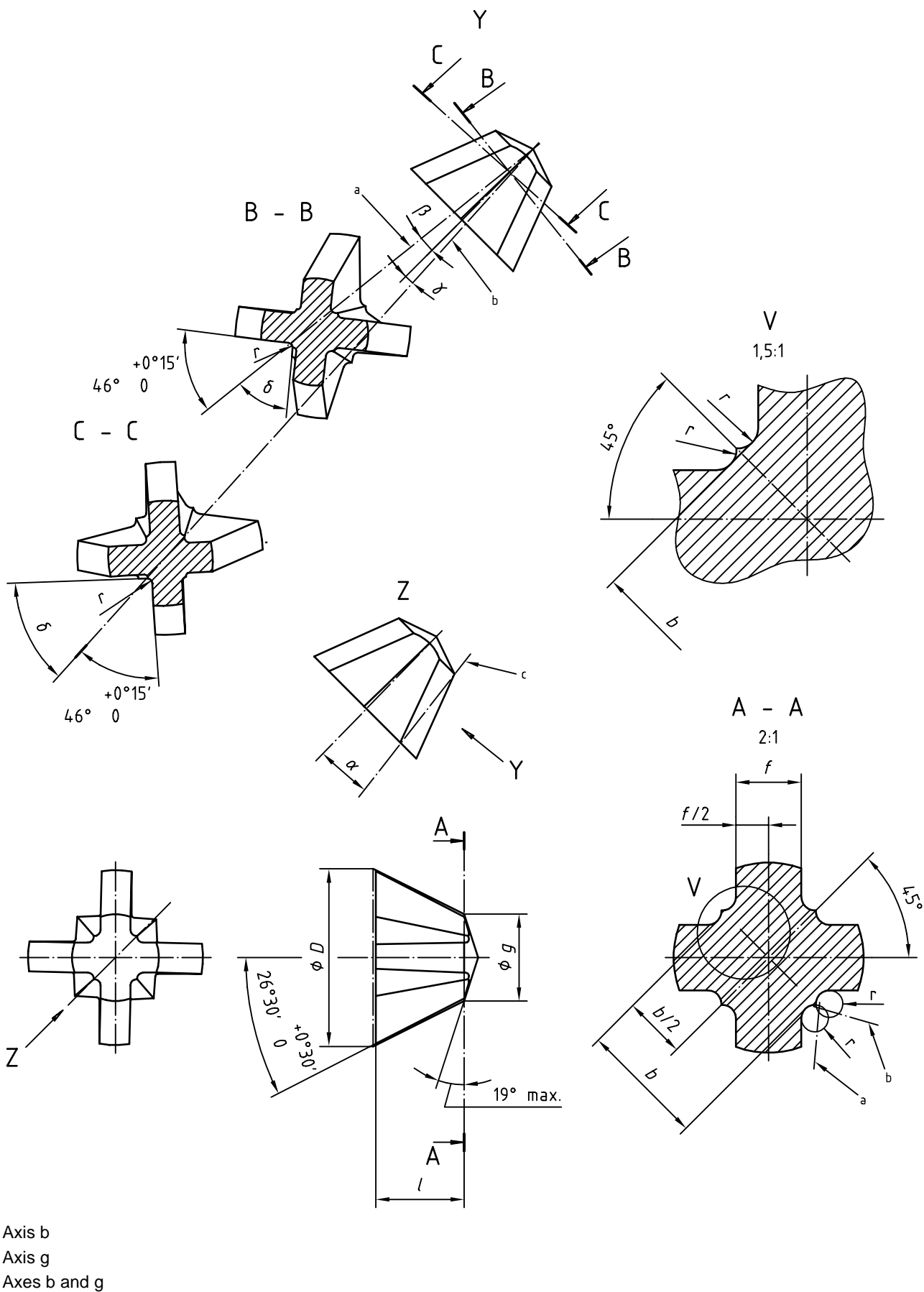

Figure 2 — Type PZ points

Table 1 — Dimensions of type PH points

Point	Nominal blade diameter mm	<i>b</i> mm	<i>e</i> mm	<i>f</i> mm	<i>g</i> mm	<i>l</i> min. mm	α	β
0	3	0,61	0,38	0,31	0,84	2,78	See Figure 1	7° 00'
		0,56	0,29	0,26	0,79			6° 30'
1	4,5	1,03	0,54	0,53	1,30	2,78	138° 30'	7° 00'
		0,98	0,49	0,48	1,25		138° 00'	6° 30'
2	6	1,56	1,13	0,64	2,31	4,37	140° 30'	5° 45'
		1,51	1,08	0,59	2,26		140° 00'	5° 15'
3	8	2,52	2,12	0,81	3,84	6,74	146° 30'	5° 45'
		2,47	2,07	0,73	3,79		146° 00'	5° 15'
4	10	3,60	2,76	1,12	5,11	8,34	153° 30'	7° 00'
		3,55	2,71	1,04	5,06		153° 00'	6° 30'

Table 2 — Dimensions of type PZ points

Point	Nominal blade diameter <i>D</i> mm	<i>b</i> mm	<i>f</i> mm	<i>g</i> mm	<i>l</i> min. mm	<i>r</i> mm	α	β	γ	δ
0	3	0,78	0,45	0,92	1,54	0,10	7° 00' 6° 30'	8° 15' 7° 45'	4° 53' 4° 23'	46° 15' 46° 00'
		0,70	0,42	0,89		0,07				
1	4,5	1,19	0,71	1,40	2,02	0,13	5° 45' 5° 15'	6° 50' 6° 20'	3° 30' 3° 00'	56° 30' 56° 15'
		1,11	0,68	1,37		0,10				
2	6	1,78	1,00	2,44	3,17	0,30	5° 45' 5° 15'	6° 50' 6° 20'	3° 30' 3° 00'	56° 30' 56° 15'
		1,70	0,95	2,39		0,15				
3	8	2,65	1,38	3,96	4	0,36	7° 00' 6° 30'	8° 15' 7° 45'	4° 53' 4° 23'	56° 30' 56° 15'
		2,55	1,33	3,91		0,20				
4	10	4,02	2,10	5,18	5,4	0,51	7° 00' 6° 30'	8° 15' 7° 45'	4° 53' 4° 23'	56° 30' 56° 15'
		3,92	2,05	5,13		0,36				

4 Technical requirements

4.1 Material

Components shall be manufactured from steel which, when suitably heat-treated, satisfies the mechanical requirements and torque tests specified in 4.2 and clause 6 respectively.

4.2 Heat treatment and hardness

The screwdriver points shall have a minimum hardness of:

- 54 HRC for hand-operated screwdrivers;
- 58 HRC for machine-operated screwdrivers;

for a minimum length of three times the nominal blade diameter measured from the driving end.

The remainder of the tool shall be hardened and tempered to a minimum of 50 HRC.

All hardness measurements shall be taken on ground flats, parallel with the axis and of sufficient area to give an accurate reading.

4.3 Finish

Components shall be free from cracks, blemishes and other deleterious defects.

5 Inspection of dimensions

Conformance with the dimensions specified in clause 3 shall be determined either by direct measurement or by the use of suitable inspection gauges as defined in 5.1 and 5.2.

5.1 Inspection gauges for type PH points

The dimensions of the points are in accordance with this part of ISO 8764 when they fit properly into the gauge and when the edges of the points at which the two cones of 53° and 142° meet and lie within step c of the gauge (see Figure 3 and Table 3) (see annex A for an explanation of the choice of dimensions).

Dimensions in millimetres

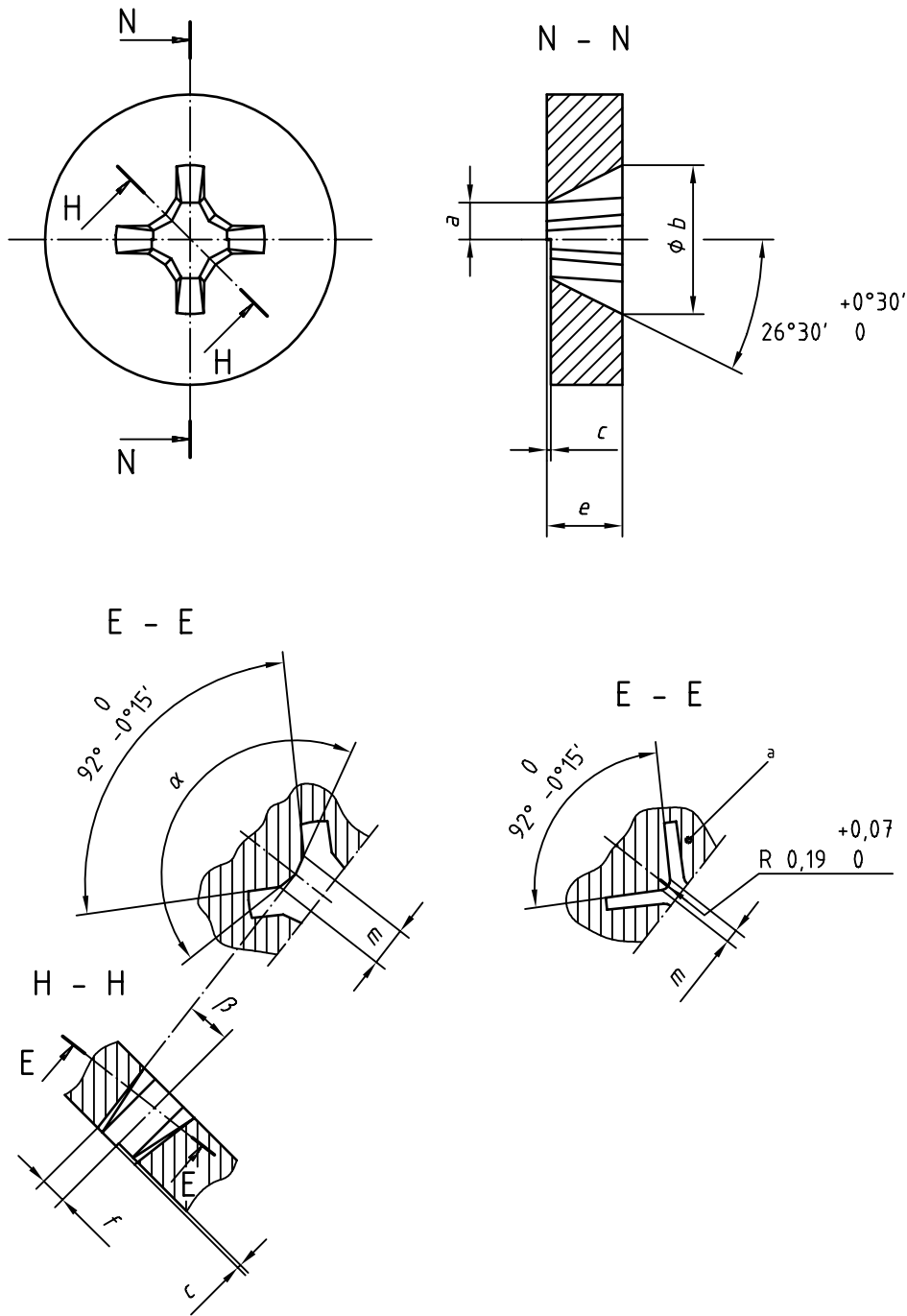

a Size No. 0

Figure 3 — Inspection gauge for type PH points

Table 3 — Dimensions of inspection gauge for type PH points

Point	a $\pm 0,005$ mm	b min. mm	c $\pm 0,025$ mm	e max. mm	f $\pm 0,005$ mm	m 0 - 0,02	α 0 - 0° 15'	β $+ 0° 15'$ 0
0	0,419	3	0,254	2,38	0,284	0,29	—	7°
1	0,648	4,5		2,38	0,493	0,49	138°	5° 45'
2	1,156	6		3,97	0,769	1,08	140°	
3	1,918	8		6,34	1,257	2,07	146°	
4	2,553	10		7,94	1,804	2,71	153°	7°

5.2 Inspection gauges for type PZ points

See Table 4 and Figure 4.

Table 4 — Dimensions of inspection gauge for type PZ points

Point	<i>b</i> mm	<i>f</i> ₁ mm	<i>f</i> ₂ mm	<i>a</i> mm	<i>i</i> mm	<i>k</i> mm	<i>g</i> mm	<i>t</i> mm	<i>r</i> _a max. mm	<i>r</i> ^{+0,05} ₀ mm	α	β	γ	δ
0	1,635	0,48	0,485	2,5	1,55	1,30	0,93	0,83	0,07	0,1	7° 10'	7° 45'	4° 23'	46° 05'
		0,47			1,54		1,29				0,92		0,82	
1	2,215	0,75	0,775	3,47	2,03	1,78	1,41	1,24	0,1	0,12	7° 10'	7° 45'	4° 23'	46° 05'
		0,74			2,02		1,77							
2	3,135	1,04	1,080	5,64	3,16	2,91	2,43	1,85	0,15	0,15	5° 55'	6° 20'	3° 00'	56° 20'
		1,03			3,15		2,90				2,42		1,84	
3	4,255	1,42	1,49	8,02	4,01	3,76	3,95	2,68	0,15	0,15	7° 10'	7° 45'	4° 23'	46° 05'
		1,41			4,00		3,75							
4	6,565	2,14	2,195	10,67	5,41	5,16	5,17	4,05	0,15	0,15	7° 10'	7° 45'	4° 23'	46° 05'
		2,13			5,40		5,15				5,16		4,04	

NOTE 1 The inspection gauge can only be used for checking the penetration depth of tool profiles. Through this the fitting precision of the tool profiles in the referring screw heads is guaranteed. The bases of this test are given in ISO 4757 (for screws) and this part of ISO 8764 (for tools).

NOTE 2 In order to make a visual test of penetration depth possible, the difference of the inspection gauge surface "*i*" and "*k*" is stated bigger than the theoretical determination of the tolerance "*g*_{min}" and "*g*_{max}".